

FORM U132

Rev. (272)

MACHINE PARTS CHART
for
SINGER*
291U

From the library of: Diamond Needle Corp

* A Trademark of THE SINGER COMPANY

© THE SINGER COMPANY 1968

Printed in Japan

SINGER*

291U1

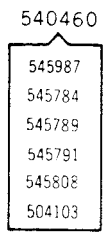
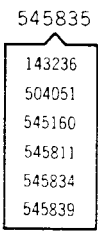
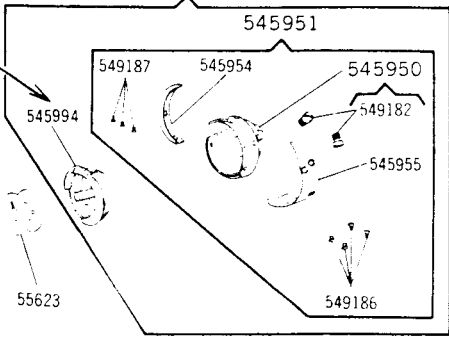
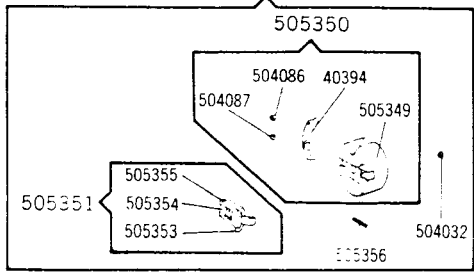
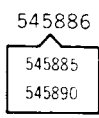
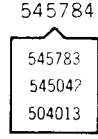
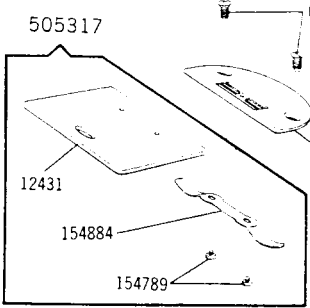
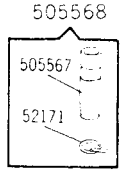
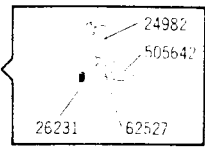
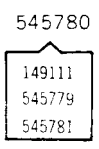
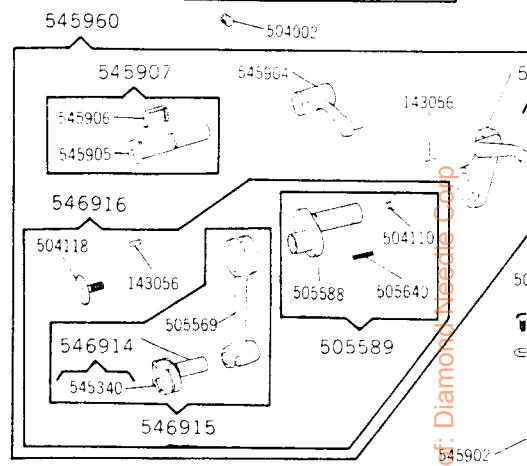
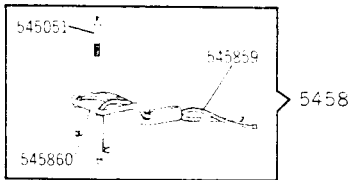
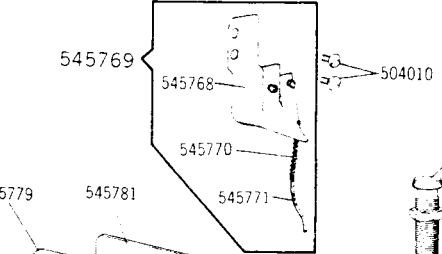
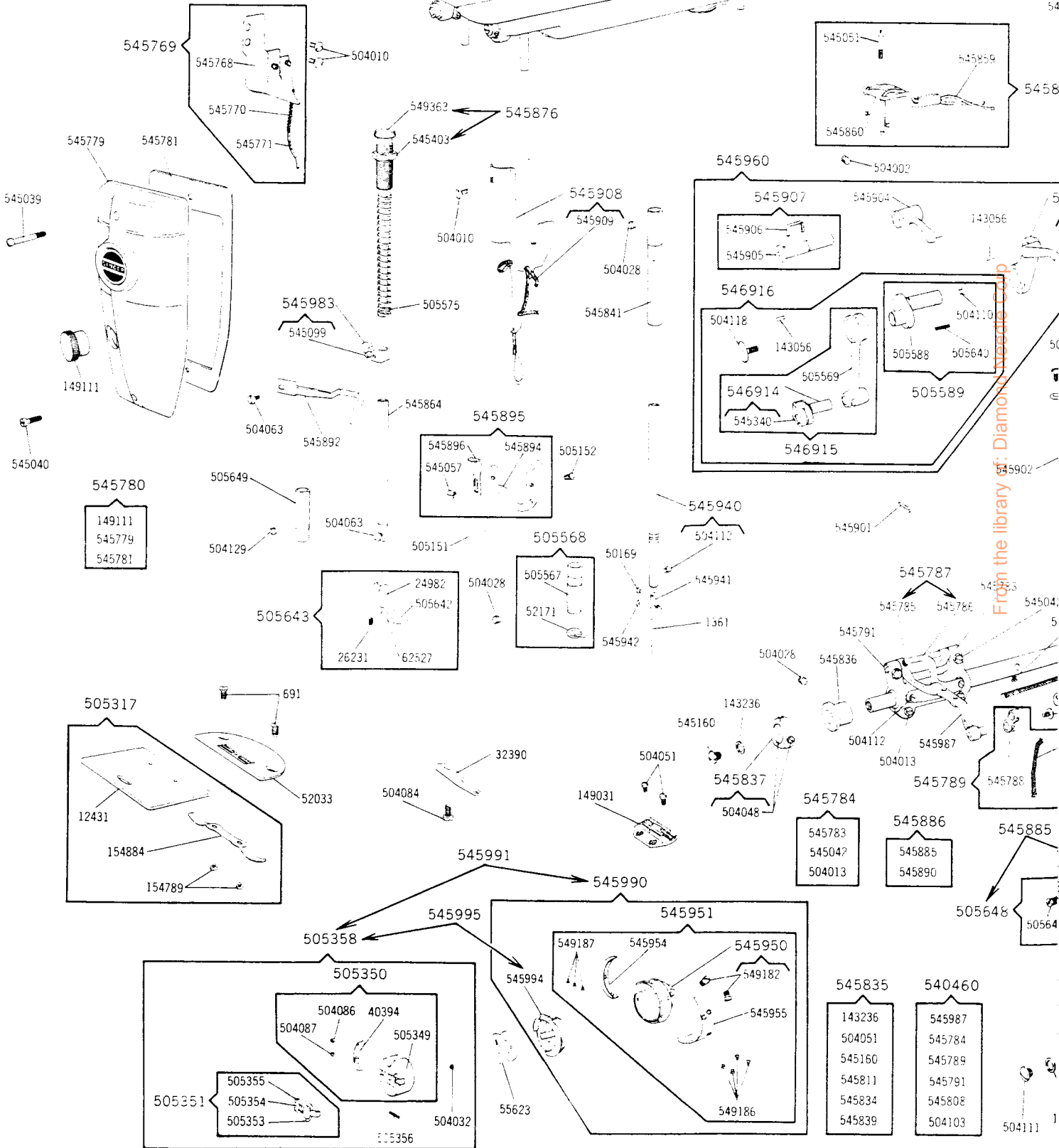
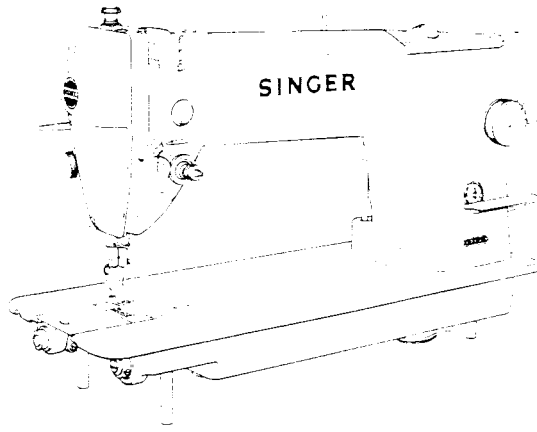

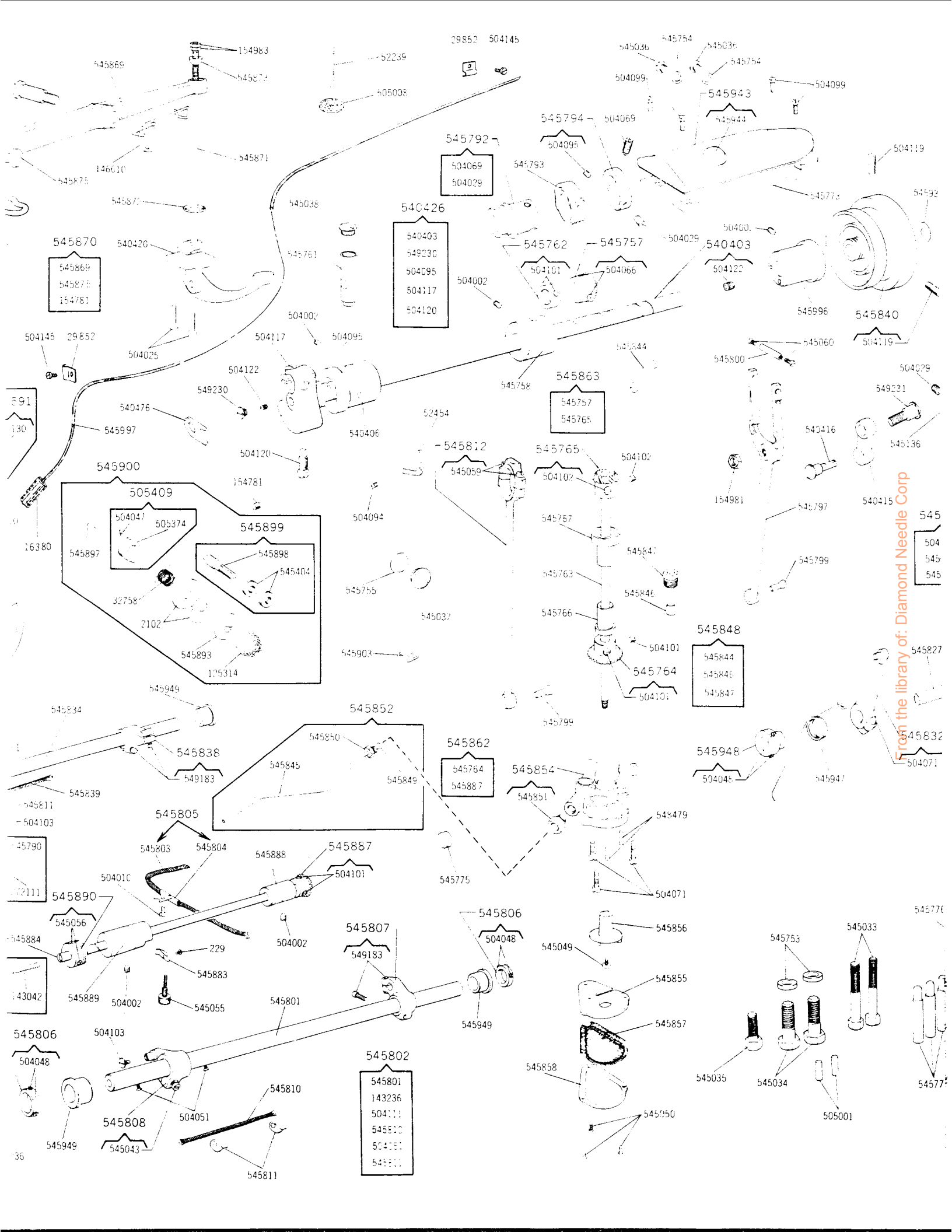

From the library of: Diamond Needle Corp

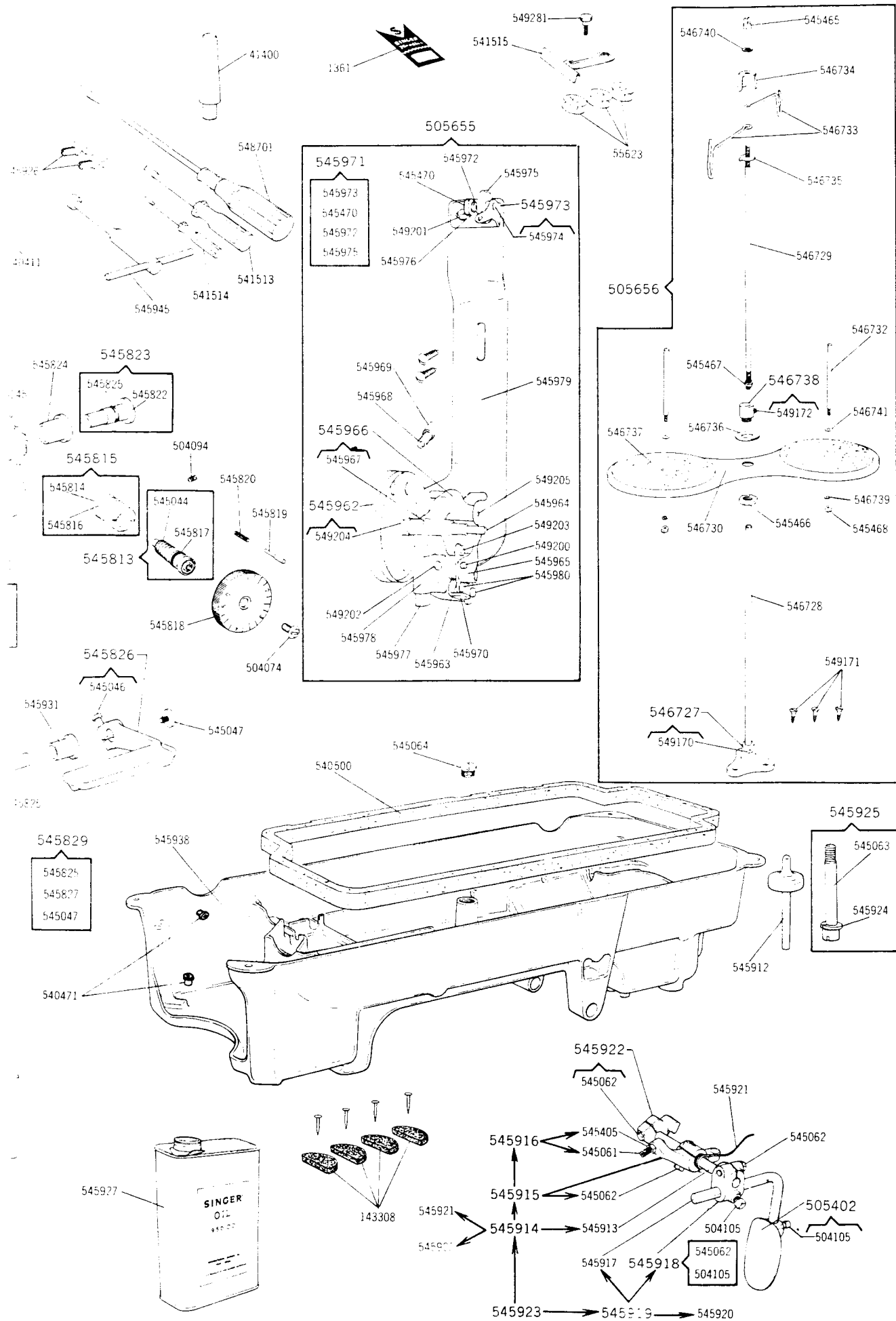

NUMERICAL LIST OF PARTS FOR MACHINE 291U1

PART NO.	DESCRIPTION	PART NO.	DESCRIPTION	PART NO.	DESCRIPTION
229 (805)	Rotating Hook Oil Flow Regulating Thumb Screw Spring Screw	504010 (829)	Arm Side Shield Screw (2)	504110 (819)	Thread Take-up Crank Oil Plug Screw
691 (850)	Throat Plate Screw (2)	504010 (829)	Feed Lifting Rock Shaft and Feed Rock Shaft Oil Wick Holder Screw	504111 (809)	Feed Lifting Rock Shaft Oil Plug Screw
2102	Tension Disc (2)	504010 (829)	Thread Take-up Lever Guard Screw	504112 (832)	Feed Bar Carrier Oil Wick Holder Screw (2)
12431	Bed Slide	504010 (829)	Thread Take-up Lever Oil Guard Screw	504112 (832)	Needle Set Screw
16380	Oil Removing Tube Lint Screen	504013 (850)	Feed Bar Carrier Clamping Screw (2)	504117 (850)	Thread Take-up Crank Clamping Screw
24982	Presser Foot Shank	504025 (850)	Bell Crank Bracket Set Screw (2)	504118 (803)	Needle Bar Connecting Link Cap Screw
26231	Presser Foot Spring	504028 (850)	Feed Rock Shaft Flanged Bushing (front) Set Screw	504119 (850)	Machine Pulley Set Screw (2)
29852	Oil Removing Tube Retaining Clamp (2)	504028 (850)	Needle Bar Bushing (lower) Set Screw	504120 (803)	Needle Bar Crank Position Screw
32390	Rotating Hook Bobbin Case Holder Position Bracket	504028 (850)	Needle Bar Bushing (upper) Set Screw	504122 (819)	Arm Shaft (horizontal) Oil Plug Screw (2)
32758	Thread Take-up Spring	504028 (850)	Needle Bar Bushing (upper) Set Screw	504129 (850)	Presser Bar Bushing (lower) Set Screw
40394	Rotating Hook Bobbin Case Tension Spring	504029 (833)	Feed and Feed Lifting Eccentric Set Screw	504145 (809)	Oil Removing Tube Retaining Clamp Screw (2)
50169 (809)	Needle Bar Thread Guard Screw	504029 (833)	Feed Regulator Screw	505001	Arm Dowel Pin (2)
52032	Throat Plate (large needle hole for 149031)	504032 (805)	Rotating Hook Bobbin Case Latch Stop Screw	505008	Arm Spool Pin Washer (felt)
52033	Throat Plate (small needle hole) for 149031	504047 (830)	Tension Stud Set Screw	505151	Tension Releasing Lever Hinge Pin
52130	Thread Take-up Lever Thread Eyelet Bushing	504048 (833)	Feed Lifting Rock Shaft Collar Set Screw (4)	505152	Tension Releasing Lever Spring
52171	Needle Bar Bushing (lower) Thread Eyelet	504048 (850)	Feed Reverse Lever Hinge Stud Collar Set Screw (2)	505317	Bed Slide complete, Nos. 12431, 154884 and two 154789 (809)
52239	Arm Spool Pin and Thread Eyelet	504048 (833)	Feed Rock Shaft Collar Set Screw (2)	505349	Rotating Hook Bobbin Case
52454	Thread Retainer	504051 (850)	Feed Dog Screw (2)	505350	Rotating Hook Bobbin Case 505349 with 40394, 504086 (806) and 504087 (806)
55623	Rotating Hook Bobbin	504051 (850)	Feed Lifting Rock Shaft Oil Wick Clamping Plate Screw (2)	505351	Rotating Hook Bobbin Case Hinge Nos. 505353, 505354 and 505355
62527	Presser Foot Hinge Pin	504063 (825)	Presser Foot Screw	505353	Rotating Hook Bobbin Case Latch
125314	Tension Spring	504063 (809)	Slack Thread Regulator Screw	505354	Rotating Hook Bobbin Case Latch Lever
140411 (802)	Arm Shaft (horizontal) Screw (back)	504066 (833)	Arm Shaft (horizontal) Bevel Gear Set Screw (2)	505355	Rotating Hook Bobbin Case Latch Lever Fulcrum Pin
143042	Rotating Hook Shaft Oil Filter Wick	504069 (833)	Feed and Feed Lifting Eccentric Position Screw	505356	Rotating Hook Bobbin Case Latch Spring
143056	Needle Bar Connecting Link Roller Bearing (18)	504071 (833)	Feed Reverse Lever Link Clamping Screw	505358	Rotating Hook Bobbin Case complete, Nos. 504032 (805), 505350, 505351 and 505356
143056	Thread Take-up Lever Roller Bearing (18)	504071 (833)	Oil Pump (centrifugal) Body Screw (3)	505374	Thread Take-up Spring Regulator
143236	Feed Lifting Rock Shaft Oil Plug Screw Washer (fiber)	504074 (852)	Feed Regulating Stud Head Cap Screw	505409	Thread Take-up Spring Regulator with 504047 (830)
143236	Feed Rock Shaft Oil Plug Screw Washer (fiber)	504084 (810)	Rotating Hook Bobbin Case Holder Position Bracket Screw	505567	Needle Bar Bushing (lower)
146610	Presser Bar Lifting Lever Spring	504086 (806)	Rotating Hook Bobbin Case Tension Regulating Screw	505568	Needle Bar Bushing (lower) with 52171
149031	Feed Dog, 19 teeth (22 teeth to the inch)	504087 (806)	Rotating Hook Bobbin Case Tension Spring Screw	505569	Needle Bar Connecting Link
149111	Face Plate Plug	504094 (850)	Feed Regulating Stud Bushing Set Screw	505575	Presser Bar Spring
154781 (850)	Presser Bar Lifting Lever Pin Set Screw	504094 (850)	Thread Retainer Set Screw	505588	Thread Take-up Crank
154781 (850)	Thread Take-up Spring Regulator Set Screw	504095 (850)	Feed and Feed Lifting Eccentric Sleeve Retaining Collar Set Screw	505589	Thread Take-up Crank with 504110 (819) and 505640
154789 (809)	Bed Slide Spring Screw (2)	504099 (809)	Arm Top Cover Screw (4)	505591	Thread Take-up Lever with 52130
154884	Bed Slide Spring	504101 (850)	Arm Shaft (horizontal) Thrust Collar Set Screw (2)	505640	Thread Take-up Crank Oil Wick
154981 (819)	Feed Connecting Link Screw Nut	504101 (850)	Arm Shaft (upright) Bevel Gear (lower) Set Screw (2)	505642	Presser Foot Plate
154983 (819)	Presser Bar Lifting Lever Connecting Rod Nut (2)	504101 (850)	Rotating Hook Shaft Bevel Gear Set Screw (2)	505643	Presser Foot (spring hinged) complete, Nos. 62527, 24982, 26231 and 505642
272111	Feed Bar Connecting Link Oil Wick Clamp	504102 (833)	Arm Shaft (upright) Bevel Gear (upper) Set Screw (2)	505647	Rotating Hook Shaft Oil Filter Wick Holder
504002 (850)	Arm Shaft (horizontal) Bushing (center) Set Screw	504103 (803)	Feed Bar Connecting Link Cap Screw (2)	505648	Rotating Hook Shaft Oil Filter complete, Nos. 143042 and 505647
504002 (850)	Arm Shaft (horizontal) Flanged Bushing (back) Set Screw				
504002 (850)	Arm Shaft (horizontal) Flanged Bushing (front) Set Screw				
504002 (850)	Rotating Hook Shaft Bushing (back) Set Screw				
504002 (850)	Rotating Hook Shaft Bushing (front) Set Screw				
504002 (850)	Thread Take-up Lever Link Hinge Stud Set Screw				

NUMERICAL LIST OF PARTS FOR MACHINE 291U1

PART NO.	DESCRIPTION	PART NO.	DESCRIPTION	PART NO.	DESCRIPTION
505649	Presser Bar Bushing (lower)	545404 (809)	Tension Regulating Thumb Nut (2)	545792	Feed and Feed Lifting Eccentric with 504069 (833) and 504029 (833)
540403	Arm Shaft (horizontal) with two 504122 (819)	545753	Arm Screw (front) Washer (2)	545793	Feed and Feed Lifting Eccentric Sleeve
540406	Arm Shaft (horizontal) Flanged Bushing (front)	545754	Arm Shaft (upright) Bevel Gear (upper) Set Screw Hole Plug Screw Gasket	545794	Feed and Feed Lifting Eccentric Sleeve Retaining Collar with 504095 (850)
540415	Feed Connecting Link	545754	Feed Regulator Set Screw Hole Plug Screw Gasket	545797	Feed Forked Connection
540416	Feed Connecting Link Stud	545755	Thread Take-up Crank Clamping Screw Hole Plug Screw Gasket	545799	Feed Forked Connection Hinge Stud
540420	Bell Crank complete	545757	Arm Shaft (horizontal) Bevel Gear with two 504066 (833)	545799	Feed Lifting Rock Shaft Crank Connecting Rod Hinge Stud
540426	Arm Shaft (horizontal) and Needle Bar Crank complete. Nos. 540403, 549230 (805), 504095 (850), 504117 (850) and 504120 (803)	545758	Arm Shaft (horizontal) Bushing (center)	545800	Feed Forked Connection Sleeve
540460	Feed Bar 545987 with 545808, 545784, 545791, 545789 and two 504103 (803)	545761	Arm Shaft (horizontal) Flanged Bushing (front) Oil Tube	545801	Feed Lifting Rock Shaft
540476	Thread Take-up Crank Wearing Plate	545762	Arm Shaft (horizontal) Thrust Collar with two 504101 (850)	545802	Feed Lifting Rock Shaft Nos. 545801, 504111 (809), 143236, 545810 and two each 545811 and 504051 (850)
545033 (805)	Arm Screw (back) (2)	545763	Arm Shaft (upright)	545803	Feed Lifting Rock Shaft and Feed Rock Shaft Oil Wick
545034 (805)	Arm Screw (front) (2)	545764	Arm Shaft (upright) Bevel Gear (lower) right hand spiral with two 504101 (850)	545804	Feed Lifting Rock Shaft and Feed Rock Shaft Oil Wick Holder
545035 (805)	Arm Screw (intermediate)		Note: To ensure proper functioning of Gears, No. 545764 will not be supplied separately, but will be substituted by Pair of Gears No. 545862.	545805	Feed Lifting Rock Shaft and Feed Rock Shaft Oil Wick Holder 545804 with 545803
545036 (819)	Arm Shaft (upright) Bevel Gear (upper) Set Screw Hole Plug Screw	545765	Arm Shaft (upright) Bevel Gear upper left hand spiral with two 504102 (833)	545806	Feed Lifting Rock Shaft Collar with two 504048 (833) (front and back)
545036 (819)	Feed Regulator Set Screw Hole Plug Screw	545766	Note: To ensure proper functioning of Gears, No. 545765 will not be supplied separately, but will be substituted by Pair of Gears No. 545863.	545807	Feed Lifting Rock Shaft Crank (back) with two 549183 (850)
545037 (819)	Thread Take-up Crank Clamping Screw Hole Plug Screw	545767	Arm Shaft (upright) Bushing (lower)	545808	Feed Lifting Rock Shaft Crank (front) with 545043 (819)
545038 (819)	Arm Shaft (horizontal) Flanged Bushing (front) Oil Tube Cap Screw	545768	Arm Shaft (upright) Bushing (upper)	545810	Feed Lifting Rock Shaft Oil Wick
545039 (809)	Face Plate Screw (long)	545769	Arm Side Shield	545811	Feed Lifting Rock Shaft Oil Wick Clamping Plate (2)
545040 (809)	Face Plate Screw (short)	545770	Arm Side Shield complete, Nos. 545768, 545770 and 545771	545811	Feed Rock Shaft Oil Wick Clamping Plate
545042 (805)	Feed Bar Hinge Pin Clamping Screw (2)	545771	Arm Side Shield Wick Spring Holder	545812	Feed Lifting Rock Shaft Crank Connecting Rod with two 545059 (810)
545043 (819)	Feed Lifting Rock Shaft Crank (front) Clamping Screw	545772	Arm Side Shield Wick	545813	Feed Regulating Stud with 545817
545044 (803)	Feed Regulating Stud	545773	Arm Top Cover Gasket	545814	Feed Regulating Stud Bushing
545045 (833)	Feed Regulator Set Screw	545775	Bed Hole Plug	545815	Feed Regulating Stud Bushing with 545816
545046 (809)	Feed Reverse Lever Clamping Screw	545776	Bed Leg (long)	545816	Feed Regulating Stud Bushing O-Ring
545047 (850)	Feed Reverse Lever Hinge Stud Cap Screw	545777	Bed Leg (short) (3)	545817	Feed Regulating Stud O-Ring
545049 (805)	Oil Pump (centrifugal) Impeller Locking Screw	545779	Face Plate	545818	Feed Regulating Stud Head complete
545050 (805)	Oil Pump (centrifugal) Screen Frame Screw (3)	545780	Face Plate complete, Nos. 545779, 545781 and 149111	545819	Feed Regulating Stud Head Lock Pin
545051 (850)	Oil Wick Holder Screw	545781	Face Plate Gasket	545820	Feed Regulating Stud Head Lock Pin Spring
545053 (850)	Presser Bar Lifter Hinge Screw	545783	Feed Bar Carrier	545821	Feed Regulator with 545045 (833), 504029 (833) and 545136 (830)
545054 (850)	Presser Bar Lifting Lever Hinge Screw	545784	Feed Bar Carrier with two each 504013 (850) and 545042 (805)	545822	Feed Regulator Hinge Stud
545055 (805)	Rotating Hook Oil Flow Regulating Thumb Screw	545785	Feed Bar Carrier Oil Wick	545823	Feed Regulator Hinge Stud with 545825
545056 (833)	Rotating Hook Shaft Oil Retaining Collar Set Screw (2)	545786	Feed Bar Carrier Oil Wick Holder	545824	Feed Regulator Hinge Stud Flanged Bushing
545057 (819)	Tension Releasing Lever Screw	545787	Feed Bar Carrier Oil Wick Holder 545786 with 545785	545825	Feed Regulator Hinge Stud O-Ring
545059 (810)	Feed Lifting Rock Shaft Crank Connecting Rod Cap Screw (2)	545788	Feed Bar Connecting Link	545825	Feed Reverse Lever Hinge Stud O-Ring
545060 (833)	Feed Forked Connection Sleeve Screw (2)	545789	Feed Bar Connecting Link 545788 with 545790 and 272111	545826	Feed Reverse Lever with 545046 (809)
545099 (803)	Presser Bar Guide Bracket Clamping and Tension Releaser Screw	545790	Feed Bar Connecting Link Oil Wick	545827	Feed Reverse Lever Hinge Stud
545136 (830)	Feed Connecting Link Stud Set Screw	545791	Feed Bar Hinge Pin		
545160 (809)	Feed Rock Shaft Oil Plug Screw				
545340 (806)	Needle Bar Connecting Stud Clamping Screw				
545403 (819)	Pressure Regulating Thumb Screw Lock Nut				

From the library of: Diamond Records Corp.

NUMERICAL LIST OF PARTS FOR MACHINE 291U1

PART NO.	DESCRIPTION	PART NO.	DESCRIPTION	PART NO.	DESCRIPTION
545829	Feed Reverse Lever Hinge Stud with 545047 (850) and 545825	545884	Rotating Hook Shaft	545954	Rotating Hook Section
545832	Feed Reverse Lever Link with 504071 (833)	545885	Rotating Hook Shaft 545884 with 505648	545955	Rotating Hook Thread Guard
545834	Feed Rock Shaft	545886	Rotating Hook Shaft 545885 with 545890	545960	Thread Take-up complete, Nos. 545907, 545904, 505591, 546916 and eighteen 143056
545835	Feed Rock Shaft Nos. 545834, 545160 (809), 143236, 545839, 545811 and 504051 (850)	545887	Rotating Hook Shaft Bevel Gear (left hand spiral) with two 504101 (850) Note: To ensure proper functioning of Gears, No. 545887 will not be supplied separately, but will be substituted by Pair of Gears No. 545862.	545982	Presser Bar Lifting Lever Link
545836	Feed Rock Shaft Flanged Bushing (front)	545888	Rotating Hook Shaft Bushing (back)	545983	Presser Bar Guide Bracket with 545099 (803)
545837	Feed Rock Shaft Collar with two 504048 (833)	545889	Rotating Hook Shaft Bushing (front)	545987	Feed Bar
545838	Feed Rock Shaft Crank with two 549183 (850)	545890	Rotating Hook Shaft Oil Retaining Collar with two 545056 (833)	545990	Rotating Hook and Rotating Hook Bobbin Case Holder Complete, Nos. 545951 and 545994
545839	Feed Rock Shaft Oil Wick	545896	Tension Releasing Lever Segment	545991	Rotating Hook, Rotating Hook Bobbin Case Holder and Rotating Hook Bobbin Case complete Nos. 545990 and 505358
545840	Machine Pulley with two 504119 (850)	545897	Tension Releasing Pin	545994	Rotating Hook Bobbin Case Holder
545841	Needle Bar Bushing (upper)	545898	Tension Stud	545995	Rotating Hook Bobbin Case 505358 with 545994 for agent only
545844	Oil Pipe for 545848	545899	Tension Stud with two 545404 (809)	545996	Arm Shaft horizontal Flanged Bushing back complete
545845	Oil Pipe for Oiling Rotating Hook Shaft (front) Bearing	545901	Thread Eyelet (side of arm)	545997	Oil Removing Tube
545846	Oil Pipe Clamping Sleeve	545902	Thread Take-up Lever Guard	546914	Needle Bar Connecting Stud with 545340 (806)
545847 (805)	Oil Pipe Clamping Sleeve Nut	545903	Thread Guard (side of arm)	546915	Needle Bar Connecting Link with 546914
545848	Oil Pipe complete from Oil Pipe to Arm Shaft (horizontal) Center Bearing, Nos. 545844, 545846 and 545847 (805)	545904	Thread Take-up Lever Link	546916	Thread Take-up Crank 505589 with 504118 (803), 546915 and eighteen 143056
545849	Oil Pipe Clamping Sleeve	545905	Thread Take-up Lever Link Hinge Stud	548479	Oil Pump centrifugal Body Position Pin 2
545850 (805)	Oil Pipe Clamping Sleeve Nut	545906	Thread Take-up Lever Link Hinge Stud Oil Wick	549182 (803)	Rotating Hook Set Screw (2)
545851	Oil Pipe Clamping Sleeve Nut Adaptor	545907	Thread Take-up Lever Link Hinge Stud with 545906	549183 (850)	Feed Lifting Rock Shaft Crank (back) Clamping Screw (2)
545852	Oil Pipe 545845 with 545849 and 545850 (805) for Oiling Rotating Hook Shaft (front) Bearing	545908	Thread Take-up Lever Oil Guard with 545909	549183 (850)	Feed Rock Shaft Crank Clamping Screw (2)
545854	Oil Pump (centrifugal) Body with 545851	545909	Thread Take-up Lever Oil Guard Wick	549186 (806)	Rotating Hook Thread Guard Screw (4)
545855	Oil Pump (centrifugal) Cover	545931	Feed Reverse Lever Hinge Stud Flanged Bushing	549187 (803)	Rotating Hook Section Screw (3)
545856	Oil Pump (centrifugal) Impeller	545932	Arm Shaft (horizontal) Screw (back) Gasket	549230 (805)	Arm Shaft (horizontal) Screw Plug (front)
545857	Oil Pump (centrifugal) Screen	545940	Needle Bar (hollow) with 504112 (832)	549231 (850)	Feed Connecting Link Screw
545858	Oil Pump (centrifugal) Screen Frame	545941	Needle Bar Thread Guard	549363 (819)	Pressure Regulating Thumb Screw
545859	Oil Wick for Oiling Thread Take-up Lever, Thread Take-up Lever Link, Needle Bar Connecting Link and Thread Take-up Lever Roller Bearing (2)	545942	Needle Bar Thread Guard Screw Washer		
545860	Oil Wick Holder	545943	Arm Top Cover with 545944	ACCESSORIES	
545861	Oil Wick Holder with two 545859 and 545051 (850)	545944	Oil Flow Window		
545862	Pair of Gears Nos. 545764 and 545887	545947	Feed Reverse Lever Link Spring	55623	Rotating Hook Bobbin (3)
545863	Pair of Gears Nos. 545757 and 545765	545948	Feed Reverse Lever Hinge Stud Collar with two 504048 (850)	541515	Cloth Guide
545864	Presser Bar (hollow)	545949	Feed Lifting Rock Shaft Flanged Bushing (2)	549281 (852)	Cloth Guide Screw
545868	Presser Bar Lifter	545949	Feed Rock Shaft Flanged Bushing (back)	545926	Machine Hinge Connection (2)
545869	Presser Bar Lifting Lever	545950	Rotating Hook with two 549182 (803)	41400	Machine Rest Pin (wood)
545870	Presser Bar Lifting Lever with 154781 (850) and 545875	545951	Rotating Hook complete Nos. 545950, 545954, 545955, three 549187 and four 549186	545927	Oil Can .950cc filled with Singer Type "C" oil
545871	Presser Bar Lifting Lever Connecting Rod			541513	Screw Driver (large)
545872	Presser Bar Lifting Lever Connecting Rod Oil Mist Retaining Disc (felt)			541414	Screw Driver (small)
545873	Presser Bar Lifting Lever Connecting Rod Swivel			548701	Screw Driver (long)
545875	Presser Bar Lifting Lever Pin			1361 (88x9)	Needle (3) (for 291U1 machine)
545876	Pressure Regulating Thumb Screw 549363 with 545403 (819)			2270 (16x257)	Needle (3) (for 291U3 machine)
545883	Rotating Hook Oil Flow Regulating Thumb Screw Spring			143308	Machine Rest (felt) (4) (with four wire nails)
				545945	Box Wrench (furnished only in special cases)

NUMERICAL LIST OF PARTS FOR MACHINE 291U1

PART NO.	DESCRIPTION	PART NO.	DESCRIPTION	PART NO.	DESCRIPTION
KNEE LIFTER PARTS					
545912	Bell Crank Plunger	545964	Bobbin Winder Spindle	546733	Thread Unwinder Thread Guide (2)
545913	Rock Shaft	545965	Bobbin Winder Stop Latch	545465 (856)	Thread Unwinder Thread Guide Lock Nut
545914	Rock Shaft 545913 with 545915, 545921 and 545922	549200 (819)	Bobbin Winder Stop Latch Screw	546740	Thread Unwinder Thread Guide Lock Nut Spring Washer
545915	Rock Shaft Crank with 545062 (833) and 545916	545970	Bobbin Winder Stop Latch Thumb Lever	546734	Thread Unwinder Thread Guide Position Cup
545061 (803)	Rock Shaft Crank Adjusting Screw	545980	Bobbin Winder Stop Latch Thumb Lever Hinge Stud 2	546735	Thread Unwinder Thread Guide Rod Washer
545916	Rock Shaft Crank Adjusting Screw 545061 (803) with 545405 (809)	549203 (819)	Bobbin Winder Stop Latch Trip Lever Hinge Screw	549171	Wood Screw 1" No. 10 (3)
545405 (809)	Rock Shaft Crank Adjusting Screw Lock Nut	545973	Bobbin Winder Tension Bracket with 545974	MACHINE BASE AND OIL RESERVOIR	
545062 (833)	Rock Shaft Crank Clamping Screw	545971	Bobbin Winder Tension complete, Nos. 545972, 545470 (819), 545973 and two 545975	545938	Machine Base and Oil Reservoir
545917	Rock Shaft Knee Arm	549201 (819)	Bobbin Winder Tension Bracket Screw	540500	Machine Base and Oil Reservoir Gasket (rubber)
545918	Rock Shaft Knee Arm Hub with 545062 (833) and 504105 (803)	545976	Bobbin Winder Tension Bracket Screw Washer	545063 (805)	Machine and Machine Base and Oil Reservoir Screw (for shipping purposes only)
545062 (833)	Rock Shaft Knee Arm Hub Clamping Screw	545975	Bobbin Winder Tension Disc (2)	545064 (805)	Machine and Machine Base and Oil Reservoir Screw Hole Plug Screw
504105 (803)	Rock Shaft Knee Arm Set Screw	545972	Bobbin Winder Tension Spring	545924	Machine and Machine Base and Oil Reservoir Screw Spring Washer (for shipping purposes only)
545919	Rock Shaft Knee Arm complete, Nos. 545917, 545918 and 545920	545974	Bobbin Winder Tension Stud	545925	Machine and Machine Base and Oil Reservoir Screw with 545924 (for shipping purposes only)
505402	Rock Shaft Knee Arm Plate with 504105 (803)	545470 (819)	Bobbin Winder Tension Stud Thumb Nut	540471	Machine Base and Oil Reservoir Plug (2)
504105 (803)	Rock Shaft Knee Arm Plate Set Screw		Wood Screw 5.5 x 19 (2)	291U3	
545921	Rock Shaft Spring	THREAD UNWINDER			
545922	Rock Shaft Stop Dog with 545062 (833)	505656	Thread Unwinder (for two spools) complete, Nos. 545465 (856), 545466 (856), 545467 (856), 546727, 546728, 546729, 546730, 546734, 546735, 546736, 546738, 546740, three 549171 and two each 545468 (856), 546732, 546733, 546737, 546739 and 546741	<i>Same as 291U1 Machine except for the following:</i>	
545062 (833)	Rock Shaft Stop Dog Clamping Screw	546732	Thread Unwinder Spool Pin (2)	149057	Feed Dog, 21 teeth (22 teeth to the inch)
545923	Rock Shaft complete, Nos. 545914 and 545919	545468 (856)	Thread Unwinder Spool Pin Nut (2)	12481	Feed Dog for 12482 (for heavy material sewing, furnished only in special cases)
BOBBIN WINDER					
505655	Universal Bobbin Winder complete, Nos. 549200 (819), 549201 (819), 549202 (819), 549203 (819), 549205, 545962, 545963, 545964, 545965, 545966, 545968, 545969, 545970, 545971, 545976, 545977, 545978, 545979 and two 545980 with two 5.5 x 19 Wood Screws	546739	Thread Unwinder Spool Pin Spring Washer (2)	505645	Needle Bar (hollow)
545979	Bobbin Winder and Tension Bracket Base	546741	Thread Unwinder Spool Pin Washer (2)	505646	Needle Bar (hollow) with 505637
545977	Bobbin Winder Brake	546738	Thread Unwinder Spool Rest Bushing with 549172 (850)	147113	Needle Bar Bushing (lower)
545978	Bobbin Winder Brake Clamp	545466 (856)	Thread Unwinder Spool Rest Bushing Nut	545937	Needle Bar Bushing (lower) 147113 with 545935
549202 (819)	Bobbin Winder Brake Clamp Screw	546736	Thread Unwinder Spool Rest Bushing Nut Washer	545935	Needle Bar Bushing (lower) Thread Eyelet
545966	Bobbin Winder Frame with 545967	549172 (850)	Thread Unwinder Spool Rest Bushing Set Screw	143327	Needle Bar Thread Guard
549205	Bobbin Winder Frame Hinge Pin	546737	Thread Unwinder Spool Rest Felt (2)	504114 (809)	Needle Bar Thread Guard Screw
545967	Bobbin Winder Frame Oil Cup	546730	Thread Unwinder Spool Rest (for two spools)	505638	Needle Clamp with 504113 (851)
545968	Bobbin Winder Frame Spring	546728	Thread Unwinder Spool Rest Rod (lower)	505637	Needle Clamp 505638 with 143327 and 504114 (809)
545969	Bobbin Winder Frame Spring Plunger	549170 (828)	Thread Unwinder Spool Rest Rod (lower) Set Screw	504113 (851)	Needle Clamp Screw
545962	Bobbin Winder Pulley with 549204 (819)	546729	Thread Unwinder Spool Rest Rod (upper)	142061	Throat Plate (large needle hole) for 149057
549204 (819)	Bobbin Winder Pulley Set Screw	545467 (856)	Thread Unwinder Spool Rest Rod (upper) Nut	127318	Throat Plate (small needle hole) for 149057
		546727	Thread Unwinder Spool Stand with 549170 (828)	12482	Throat Plate (for 12481, for heavy material sewing, furnished only in special cases)

From the library of: Dartford Needle Corp